

DRAINAGE

| <u>NUMBER</u> | <u>TITLE</u> |
|---------------|-----------------------------------|
| D-01.0 | DROP INLET NOTES |
| D-01.1 | DROP INLET - TYPE 1 |
| D-01.2 | DROP INLET - TYPE 2 |
| D-02.0 | DROP INLET DETAIL NOTES |
| D-02.1 | DROP INLET THROAT AND STEP DETAIL |
| D-03.0 | GUTTER DEPRESSION - TYPE A |
| D-03.1 | GUTTER DEPRESSION - TYPE A1 |
| D-04.0 | GUTTER DEPRESSION - TYPE B |
| D-04.1 | GUTTER DEPRESSION - TYPE B1 |
| D-05.0 | CURB OUTLET DRAIN - TYPE A |
| D-05.1 | CURB OUTLET DRAIN - TYPE B |
| D-05.2 | CURB OUTLET DRAIN - TYPE C |
| D-06.0 | PIPE HEADWALL |



DRAINAGE TABLE OF CONTENTS

| | | |
|--------------------|----------------------------|----------------|
| STREETS: <i>mw</i> | REV. DATE: 11/12 | DETAIL: D-00.0 |
| TRANS OPS: | APPROVED: <i>Pat Kelly</i> | |
| FACILITIES: | CITY ENGINEER | |
| WATER RESOURCES: | <i>Christina Anderson</i> | |
| | PUBLIC WORKS DIRECTOR | |

DROP INLET NOTES:

1. All concrete shall be Class 560-C-3250 per Standard Specifications for Public Works Construction. (GREEN BOOK)
2. The curb opening shall be as shown on plan, but not less than 4 feet for Type 1, 10 feet for Type 2.
3. Install step when required, per Standard Detail D-02.0 and D-02.1.
4. Connector pipe shall be placed on the back or side wall as shown in plans, to be clear of future drop inlet filter baskets.
5. Provide 3 inch radius rounded edge at pipe inlet.
6. The width of gutter depression shall be 4 feet unless otherwise shown on plans.
7. Manhole frame and cover shall be Alhambra Foundry A-1530B lettered with the words "City of Santa Barbara Storm Drain" unless otherwise specified in plans.
8. Top slab surface shall be a light broom finish.
9. See Standard Detail D-02 for drop inlet throat and step detail.
10. Gutter depression shall be Type A, Standard Detail D-03.0 unless otherwise specified on plans.
11. Reinforcing steel in the top slab shall be #4 @12 inches on center.
12. Wall thickness (T) and reinforcing requirements shall be per Table A, Standard Details D-01.1 and D-01.2.
13. Clear drying fugitive dye curing compound shall be applied to all exposed surfaces immediately after finishing.
14. Aggregate base shall be placed 6 inches deep and compacted to 95% minimum relative compaction on undisturbed native soil before placing concrete.
15. Manhole shall be set 6 inches from inside wall of inlet.
16. All interior walls, floor, and top shall be sacked and patched upon completion.
17. Extend top slab rebar 4" into walls of drop inlet and 12" into adjacent curbs.
18. Install "Drains to Ocean" medallion on top slab per Standard Details D-01.1 and D-01.2.
19. Where required, an American Storm Water "Surf Gate" catch basin debris screen shall be installed.
20. Reference "Greenbook" Standard Plans for Public Works Construction for details for connector pipe to storm drain pipe connections.



DROP INLET NOTES

| | | |
|-----------------------|--|----------------|
| STREETS: <i>no</i> | REV. DATE: 11/12 | DETAIL: D-01.0 |
| TRANS OPS: | APPROVED: <i>Pat Gelf</i> | |
| FACILITIES: | CITY ENGINEER | |
| WATER RESOURCES: | <i>Christina Anderson</i> PUBLIC WORKS DIRECTOR | |

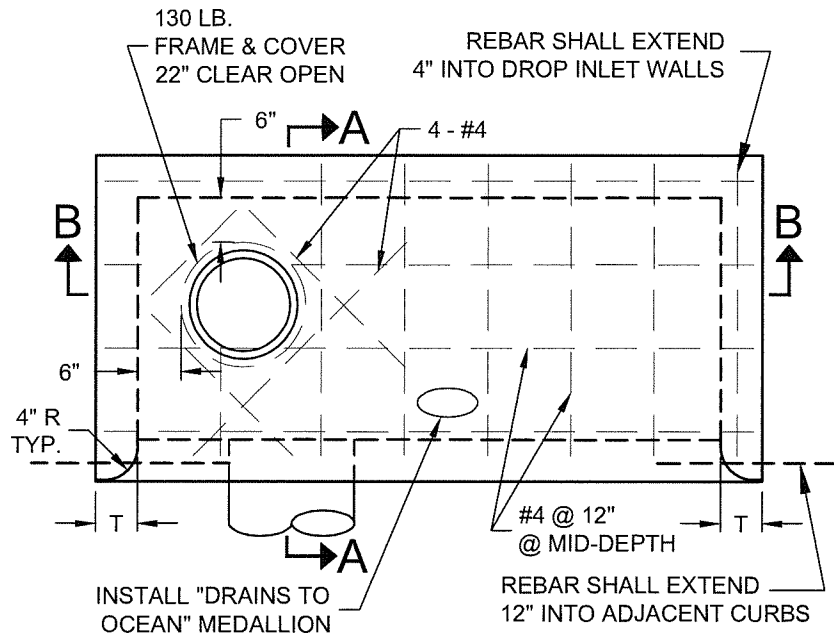

PLAN

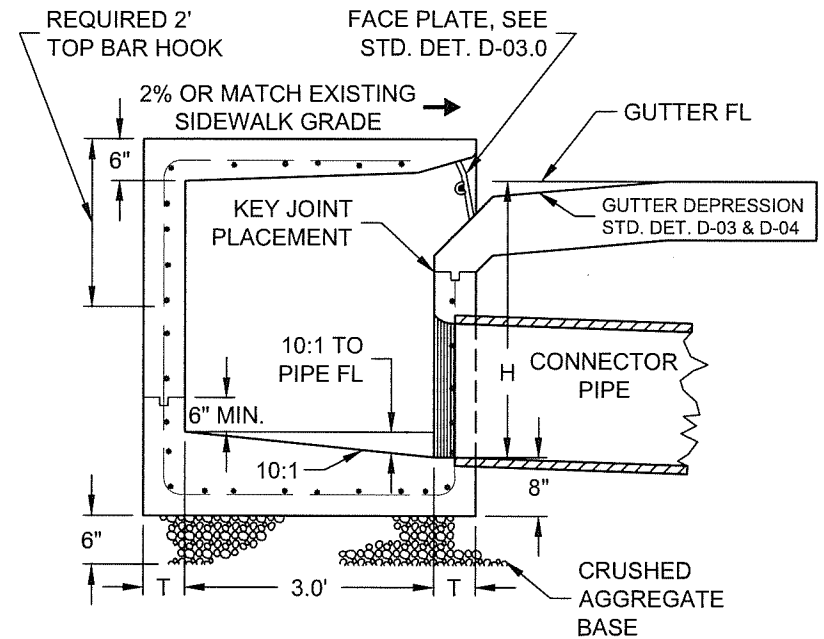

SECTION A-A

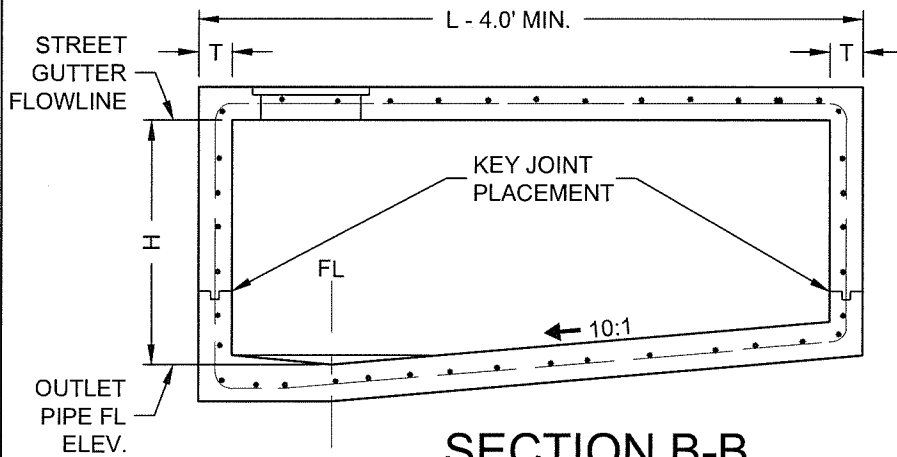

SECTION B-B

| | CONCRETE | | REINFORCING | | |
|-----------------|----------|----------|-------------|--------|--------|
| | H RANGE | T (TYP.) | BOTTOM | SIDES | TOP |
| LESS THAN 4' | 6" | NONE | NONE | NONE | #4@12" |
| 4' - 8' | 8" | NONE | NONE | NONE | #4@12" |
| *4' - 8' | 6" | #4@18" | #4@18" | #4@18" | #4@12" |
| GREATER THAN 8' | 8" | #4@12" | #4@12" | #4@12" | #4@12" |

*OPTIONAL

TABLE A



DROP INLET

TYPE 1

| | | |
|--------------------|--|----------------|
| STREETS: <i>MO</i> | REV. DATE: 11/12 | DETAIL: D-01.1 |
| TRANS OPS: | APPROVED: <i>Pat Kelly</i> | |
| FACILITIES: | CITY ENGINEER | |
| WATER RESOURCES: | <i>Christopher Anderson</i> PUBLIC WORKS DIRECTOR | |

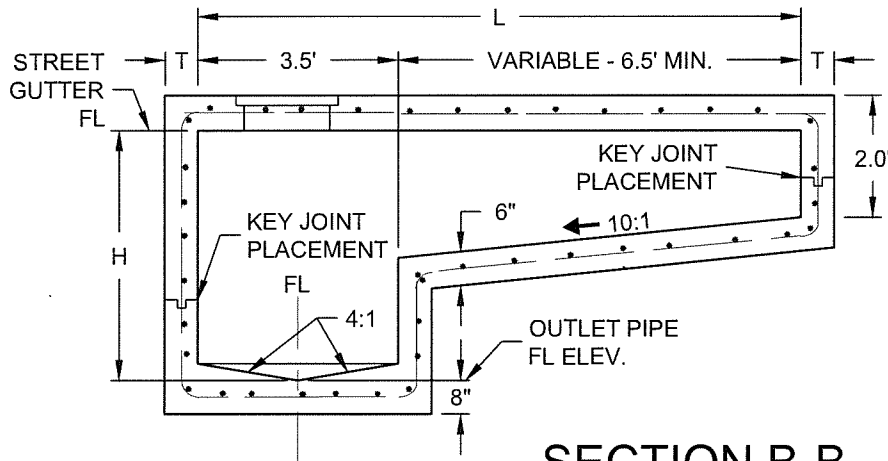
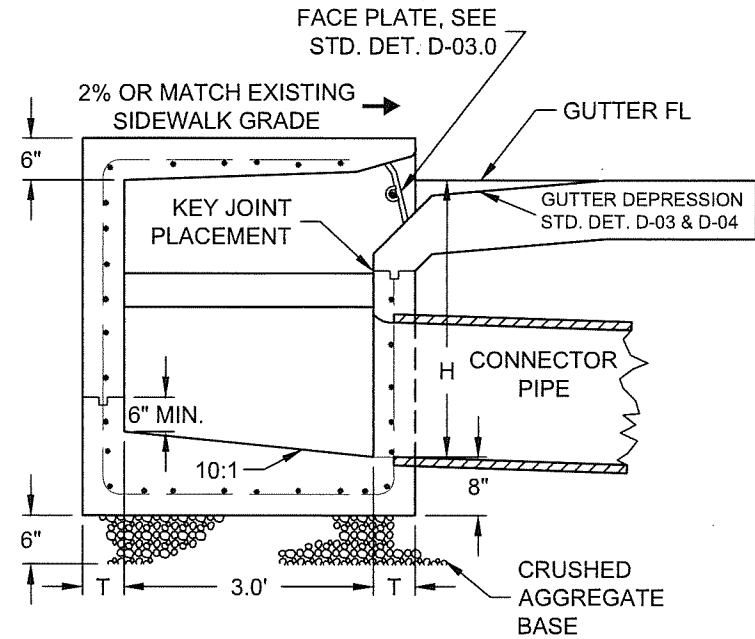
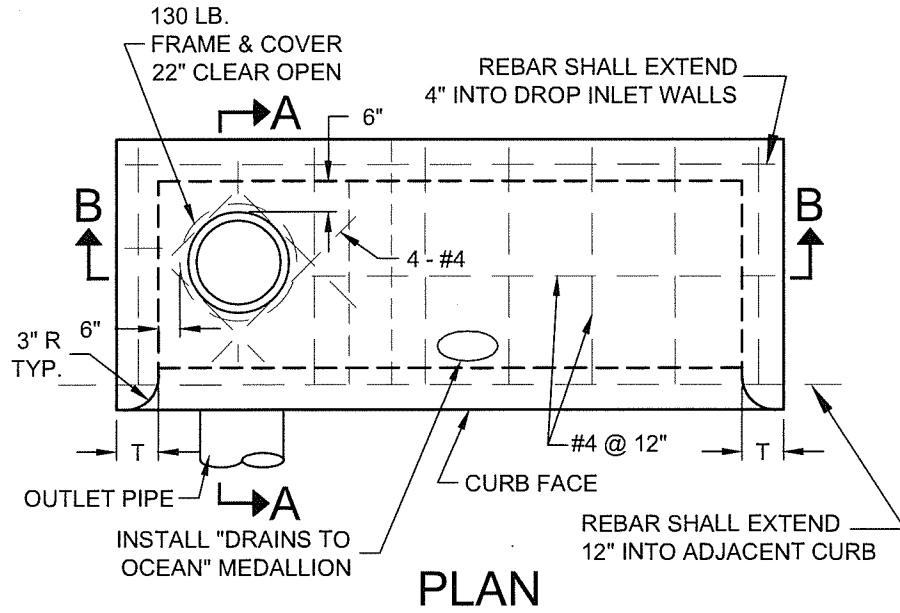

| | CONCRETE | | REINFORCING | | |
|-----------------|----------|----------|-------------|--------|--------|
| | H RANGE | T (TYP.) | BOTTOM | SIDES | TOP |
| *LESS THAN 5' | 8" | 8" | NONE | NONE | #4@12" |
| 5' - 8' | 8" | 8" | NONE | NONE | #4@12" |
| **5' - 8' | 6" | 6" | #4@18" | #4@18" | #4@12" |
| GREATER THAN 8' | 8" | 8" | #4@12" | #4@12" | #4@12" |

*REQUIRES SPECIAL APPROVAL BY ENGINEER OR DESIGNEE
**OPTIONAL

TABLE A



DROP INLET TYPE 2

| | | |
|--------------------|--|----------------|
| STREETS: <i>mn</i> | REV. DATE: 11/12 | DETAIL: D-01.2 |
| TRANS OPS: | APPROVED: <i>Pat Kelly</i> | |
| FACILITIES: | CITY ENGINEER | |
| WATER RESOURCES: | <i>Christopher Anderson</i> PUBLIC WORKS DIRECTOR | |

DROP INLET DETAIL NOTES:

1. Face plate shall be Alhambra Foundry A-3912 or approved equal, embedded 3 inches into side walls.
2. Support bolts shall be installed, when curb opening exceeds 7 feet and shall be spaced evenly not more than 7 feet and not less than 5 feet on center.
3. 3/4 inch diameter longitudinal protection bar assembly shall be installed when inlet curb face is more than 9 inches. The protection bar shall be fitted to each support bolt.
4. Steps are not required when H is 3.5 feet or less (see Standard Details D-01.1 and D-01.2). Install one step 16 inches above the floor when H is greater than 3.5 feet but less than 5 feet. Install steps at 12 inch intervals when H exceeds 5 feet. Steps shall be non-slip polypropylene plastic coated reinforcing steel complying with all current ASTM standards. Any exposed metal parts shall be galvanized after fabrication.
5. Inlet opening shall be equal to the existing curb height plus 3 inches.
19. Where required, an American Storm Water "Surf Gate" catch basin debris screen shall be installed.



DROP INLET DETAIL NOTES

| | | | |
|------------------|-----------|---------------------------|-----------------------|
| STREETS: | <i>mu</i> | REV. DATE: 11/12 | DETAIL: D-02.0 |
| TRANS OPS: | | APPROVED: | <i>Pat Kelly</i> |
| FACILITIES: | | CITY ENGINEER | |
| WATER RESOURCES: | | <i>Christina Andersen</i> | PUBLIC WORKS DIRECTOR |

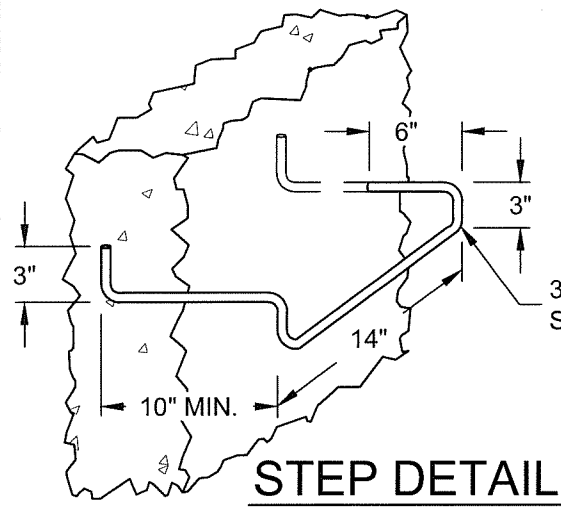
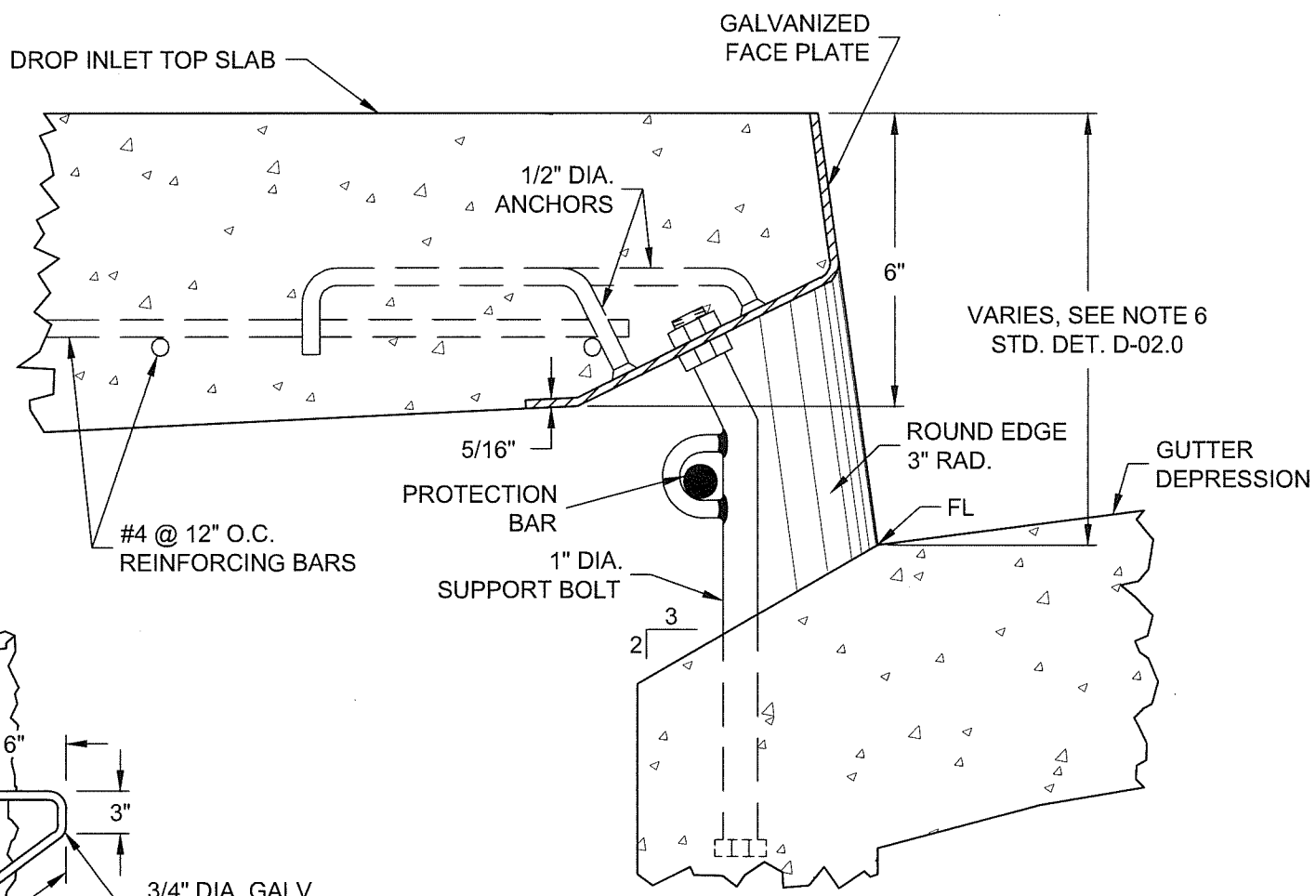

NOTE: FIRST RUNG SHALL BE MOUNTED NO GREATER THAN 12 INCHES BELOW THE TOP EXTERIOR OF THE DROP INLET

TYPICAL SECTION OF DROP INLET THROAT



DROP INLET THROAT AND STEP DETAIL

| | | |
|--------------------|--|----------------|
| STREETS: <i>mu</i> | REV. DATE: 11/12 | DETAIL: D-02.1 |
| TRANS OPS: | APPROVED: <i>Pat Kelly</i> | |
| FACILITIES: | CITY ENGINEER | |
| WATER RESOURCES: | <i>Christopher Anderson</i> PUBLIC WORKS DIRECTOR | |

NOTES:

1. Gutter depression, curb transition and structure's top slab shall be poured monolithic.
2. Surface finish of gutter depression shall be light broom finish.
3. Concrete strength and curing compound per Standard Detail D-01.0.
4. Gutter depression shall be 3 inches.
5. Deep joint shall be 2 inches deep.

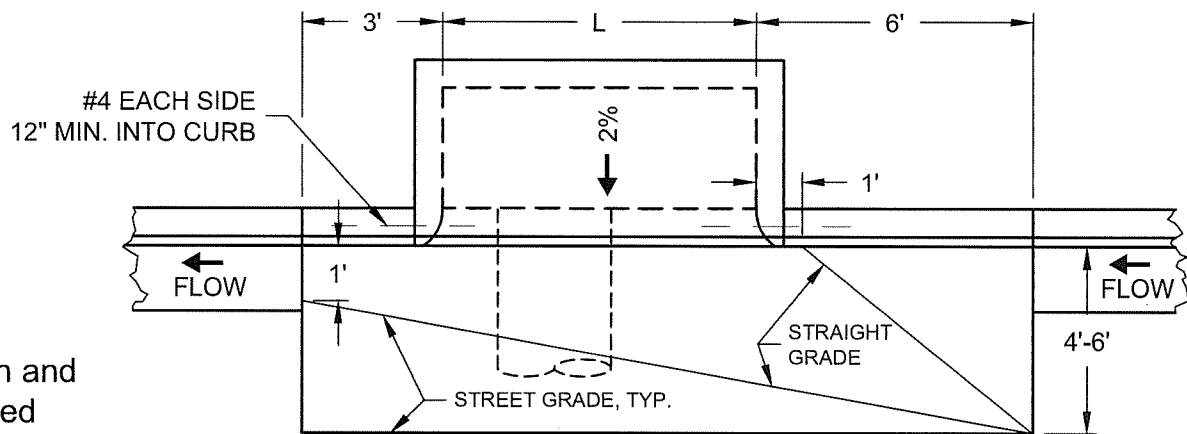

PLAN - INLET ON GRADE

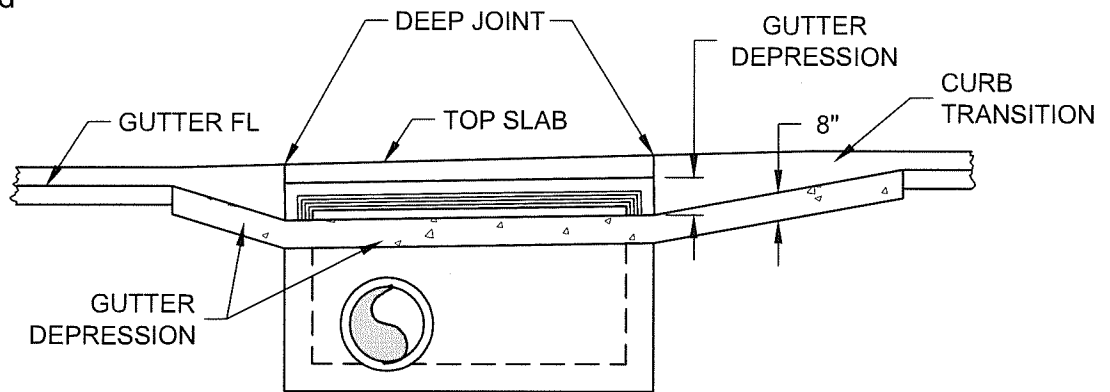

SECTION AT GUTTER FL



**GUTTER DEPRESSION
TYPE A**

| | | |
|--------------------|--|----------------|
| STREETS: <i>40</i> | REV. DATE: 11/12 | DETAIL: D-03.0 |
| TRANS OPS: | APPROVED: <i>Pat Kelly</i> | |
| FACILITIES: | CITY ENGINEER | |
| WATER RESOURCES: | <i>Christina Anderson</i> PUBLIC WORKS DIRECTOR | |

NOTES:

1. Gutter depression, curb transition and structure's top slab shall be poured monolithic.
2. Surface finish of gutter depression shall be light broom finish.
3. Concrete strength and curing compound per Standard Detail D-01.0.
4. Gutter depression shall be 3 inches.
5. Deep joint shall be 2 inches deep.

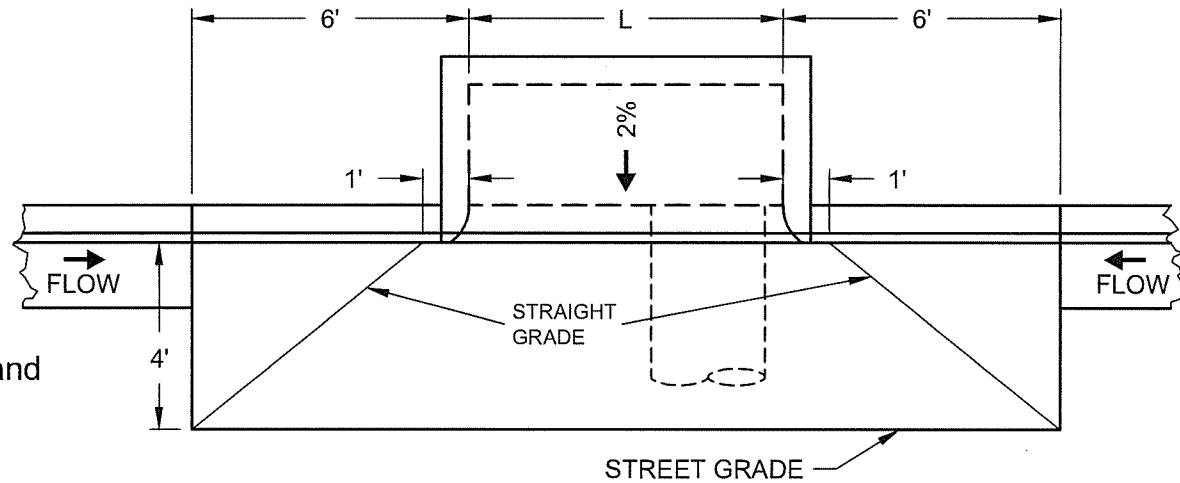

PLAN - INLET IN SAG

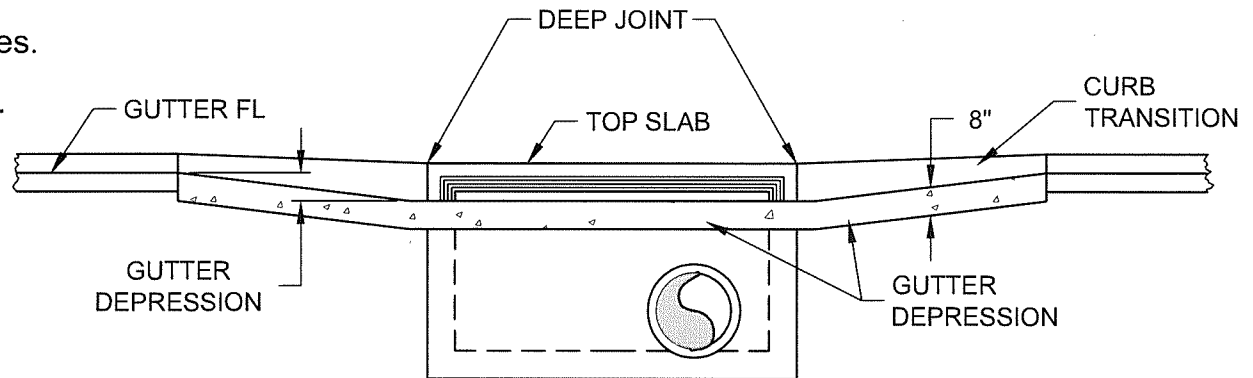

SECTION AT GUTTER FL



GUTTER DEPRESSION

TYPE A1

| | | |
|--------------------|--|----------------|
| STREETS: <i>MA</i> | REV. DATE: 11/12 | DETAIL: D-03.1 |
| TRANS OPS: | APPROVED: <i>Pat Kelly</i> | |
| FACILITIES: | CITY ENGINEER | |
| WATER RESOURCES: | <i>Christopher P. ...</i> PUBLIC WORKS DIRECTOR | |

NOTES:

1. Gutter depression, curb transition and structure's top slab shall be poured monolithic.
2. Surface finish of gutter depression shall be light broom finish.
3. The width of the depressed gutter shall match street gutter width.
4. Concrete strength and curing compound per Standard Detail D-01.0.
5. Gutter depression shall be 3 inches.
6. Deep joint shall be 2 inches deep.

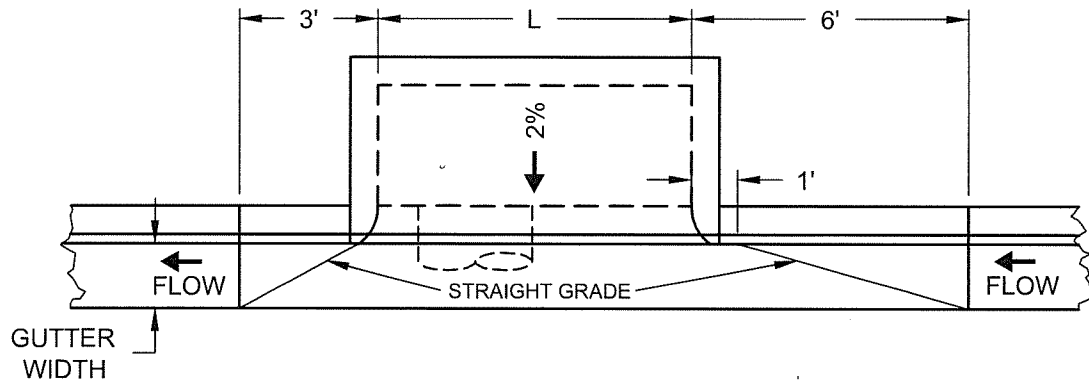

PLAN - INLET ON GRADE

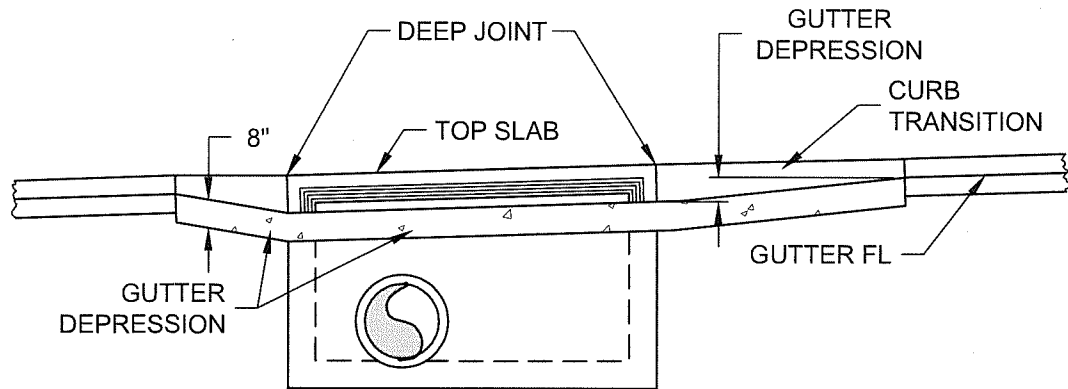

SECTION AT GUTTER FL



**GUTTER DEPRESSION
TYPE B**

| | | |
|--------------------|----------------------------|----------------|
| STREETS: <i>mu</i> | REV. DATE: 11/12 | DETAIL: D-04.0 |
| TRANS OPS: | APPROVED: <i>Pat Kelly</i> | |
| FACILITIES: | CITY ENGINEER | |
| WATER RESOURCES: | <i>Christina Anderson</i> | |
| | PUBLIC WORKS DIRECTOR | |

NOTES:

1. Gutter depression, curb transition and structure's top slab shall be poured monolithic.
2. Surface finish of gutter depression shall be light broom finish.
3. The width of the depressed gutter shall match street gutter width.
4. Concrete strength and curing compound per Standard Detail D-01.0.
5. Gutter depression shall be 3 inches.
6. Deep joint shall be 2 inches deep.

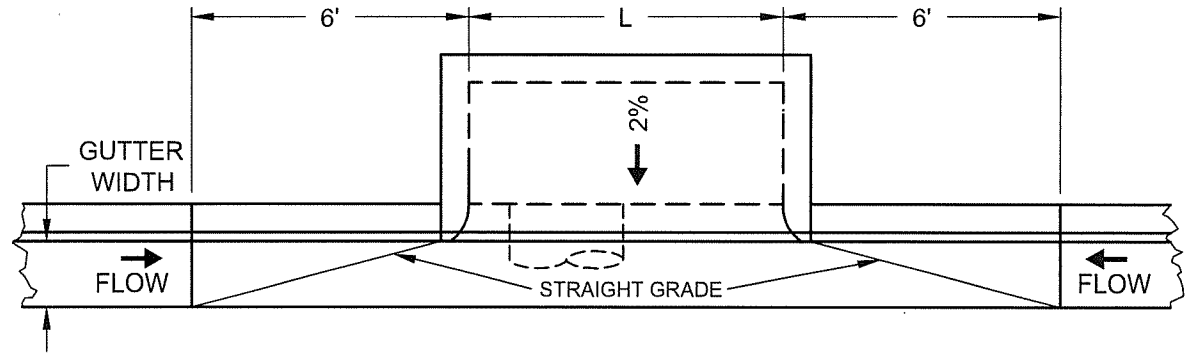

PLAN - INLET IN SAG

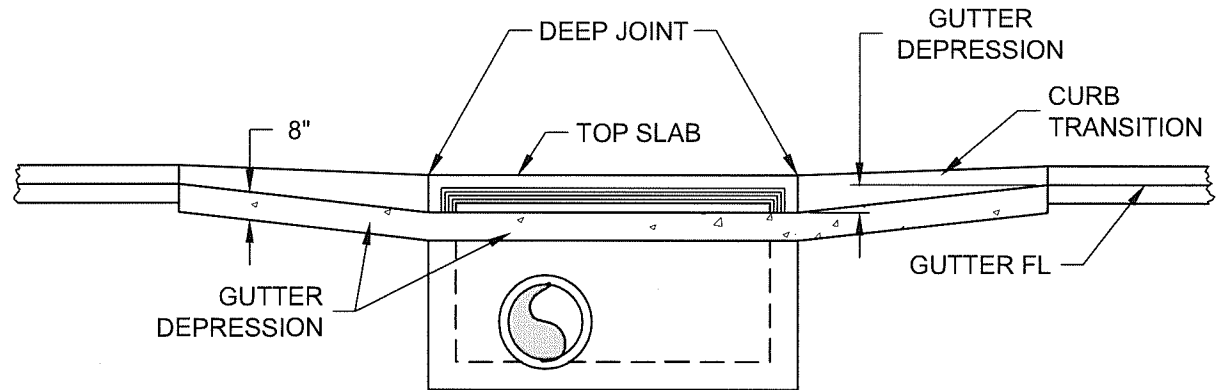

SECTION AT GUTTER FL



**GUTTER DEPRESSION
TYPE B1**

| | | |
|--------------------|--|----------------|
| STREETS: <i>MA</i> | REV. DATE: 11/12 | DETAIL: D-04.1 |
| TRANS OPS: | APPROVED: <i>Pat Bell</i> | |
| FACILITIES: | CITY ENGINEER | |
| WATER RESOURCES: | <i>Christine Anderson</i> PUBLIC WORKS DIRECTOR | |

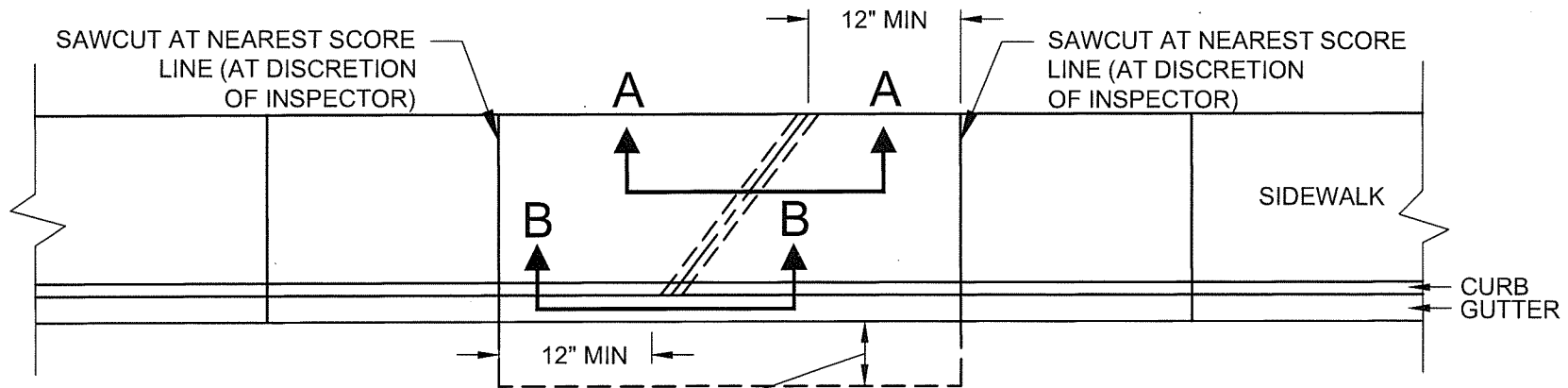

REMOVE 18" MIN PAVEMENT AND REPLACE

PLAN

NOTES:

1. Drain shall be schedule 40 P.V.C.
2. Replace sidewalk per Standard Details H-06.0 and H-06.1
3. Replace curb and gutter per Standard Detail H-02.
4. A maximum 3 inch diameter pipe shall be used in a 6 inch curb, 4 inch pipe in an 8 inch curb.
5. Pipe(s) shall have a minimum 0.5%, maximum 2% positive slope.
6. The number of pipes at any location shall not exceed four. There shall be a 3 inch minimum clearance between all pipes.
7. In commercial areas, sawcut and remove sidewalk, curb, and gutter per plan above.
8. In residential areas, remove a minimum of one panel length of sidewalk, curb, and gutter. Dowel into gutter.
9. Pipe opening may be core-drilled in existing curb in lieu of curb removal.
10. Property owners are responsible for curb drain maintenance.
11. Curb drain shall be placed a minimum of 5 feet (10 feet preferred) from any driveway, City tree, or intersection curb return.

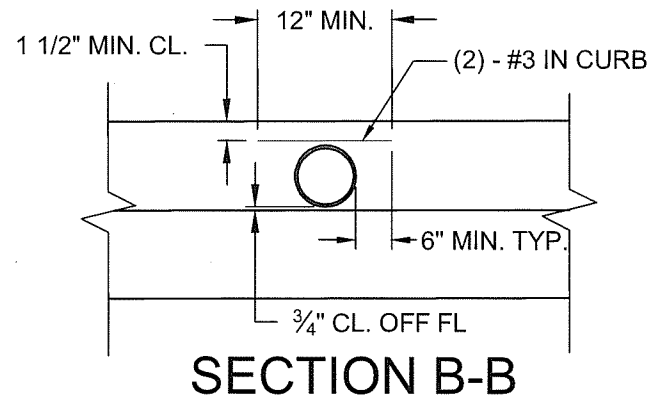
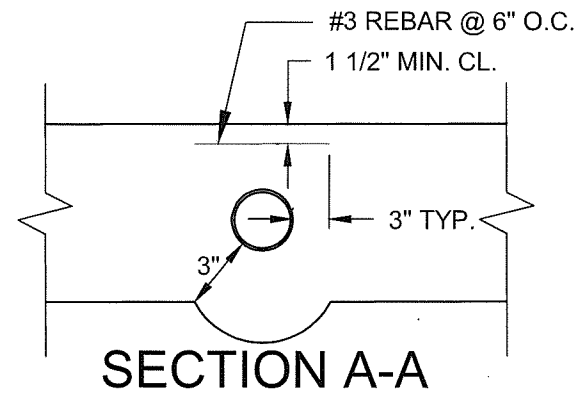

CURB OUTLET DRAIN
TYPE A

| | | | |
|------------------|--------------------|--------------------|-----------------------|
| STREETS: | <i>[Signature]</i> | REV. DATE: 11/12 | DETAIL: D-05.0 |
| TRANS OPS: | | APPROVED: | <i>[Signature]</i> |
| FACILITIES: | | CITY ENGINEER | |
| WATER RESOURCES: | | <i>[Signature]</i> | PUBLIC WORKS DIRECTOR |

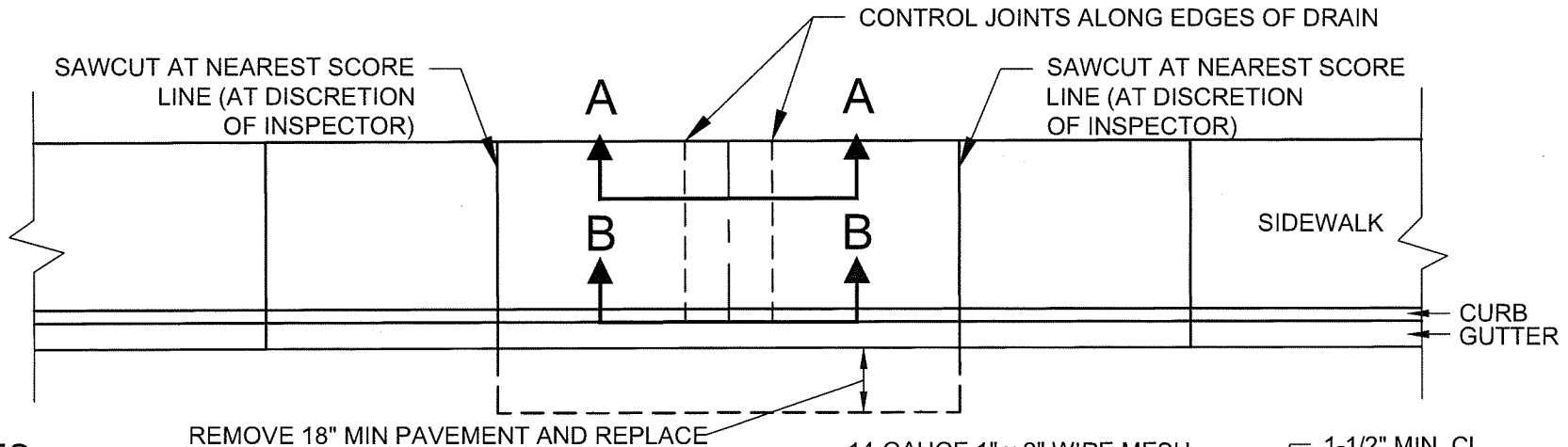

NOTES:

1. Drain shall be Alhambra Foundry A-470 Rectangular Cast Iron Pipe.
2. Where curb height is less than 8 inches, sidewalk may be raised such that the curb height reaches 8 inches at the drain outlet if approved by City inspector.
3. Where curb height is less than 8 inches and sidewalk modification is not possible, a Type A (D-5.0) or Type C (D-05.2) drain shall be used.
4. Replace sidewalk per Standard Details H-06.0 and H-06.1.
5. Replace curb and gutter per Standard Detail H-02.0.
6. Pipe(s) shall have a minimum 0.5%, maximum 2% positive slope.
7. In commercial areas, sawcut and remove sidewalk, curb, and gutter per plan above.
8. In residential areas, remove a minimum of one panel length of sidewalk, curb, and gutter. Dowel into gutter.
9. Property owners are responsible for curb drain maintenance.
10. Curb drain shall be placed a minimum of 5 feet (10 feet preferred) from any driveway, City tree, or intersection curb return.

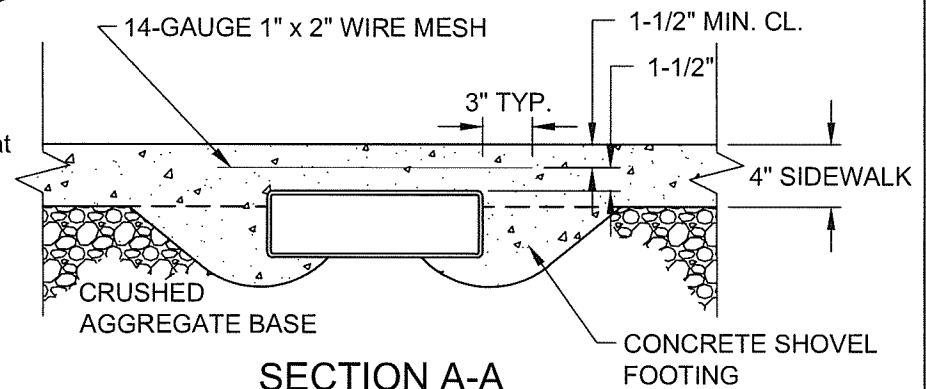

SECTION A-A

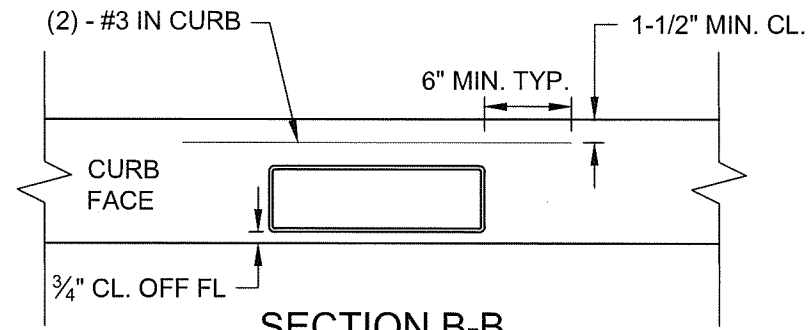

SECTION B-B



CURB OUTLET DRAIN

TYPE B

| | | | |
|------------------|-----------|---------------------------|----------------|
| STREETS: | <i>mu</i> | REV. DATE: 11/12 | DETAIL: D-05.1 |
| TRANS OPS: | | APPROVED: | |
| FACILITIES: | | <i>Pat Kelly</i> | |
| WATER RESOURCES: | | CITY ENGINEER | |
| | | <i>Christina Pedersen</i> | |
| | | PUBLIC WORKS DIRECTOR | |

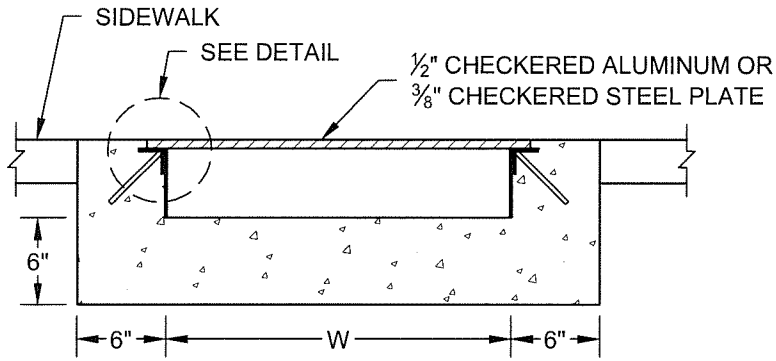

SECTION B-B

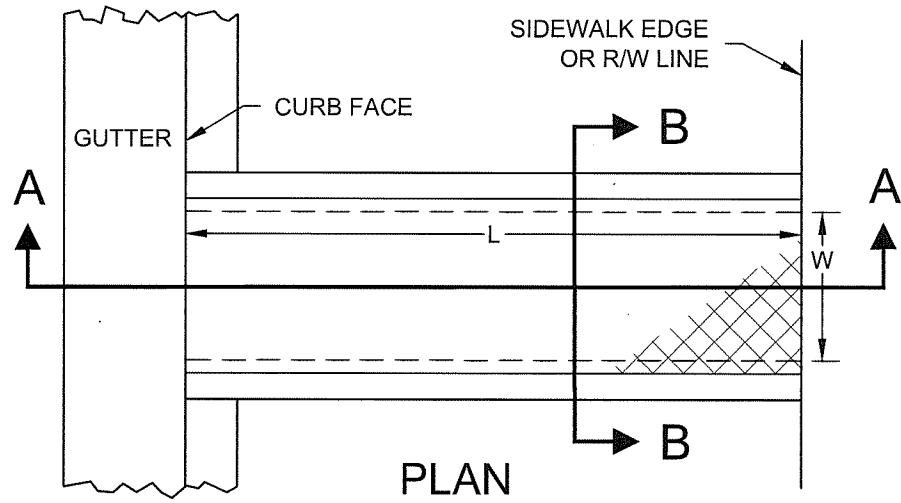

PLAN

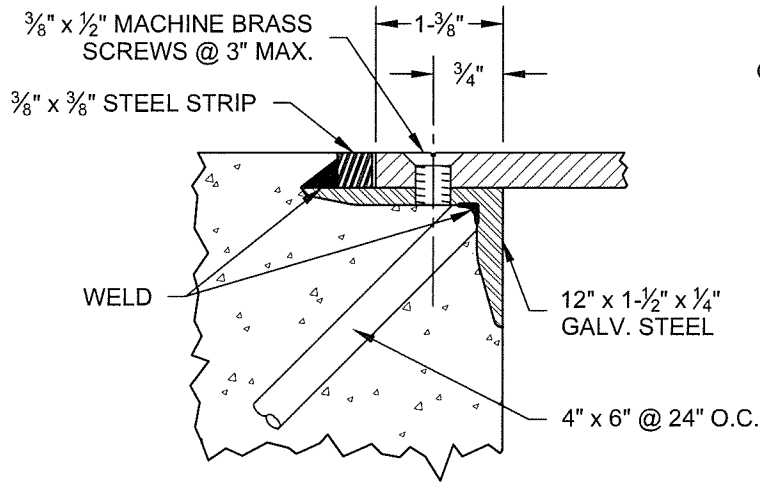

DETAIL

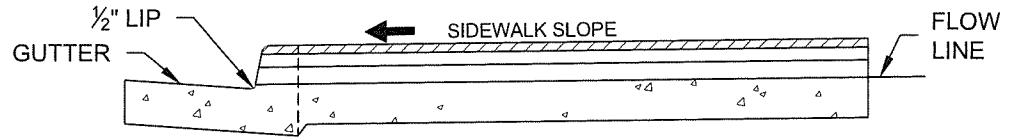

SECTION A-A

NOTES:

1. L - Length of sidewalk drain as shown on Plans.
2. W - Width of sidewalk drain as shown on Plans, 2' maximum. Widths exceeding 2' shall be approved by City Engineer.
3. Concrete - Class 560-C-3250 per Standard Specifications for Public Works Construction.
4. 3/8" X 3/8" steel strip - tack welded to angle at 12°.
5. All exposed steel to be galvanized after fabrication.
6. For use only when Type A or B curb outlet drain cannot feasibly be installed.
7. Drain shall be a minimum of 10 feet from any driveway or alley entrance.



**CURB OUTLET DRAIN
TYPE C**

| | | |
|--------------------|--|----------------|
| STREETS: <i>mu</i> | REV. DATE: 11/12 | DETAIL: D-05.2 |
| TRANS OPS: | APPROVED: <i>Pat Kelly</i> | |
| FACILITIES: | CITY ENGINEER | |
| WATER RESOURCES: | <i>Christina Anderson</i> PUBLIC WORKS DIRECTOR | |

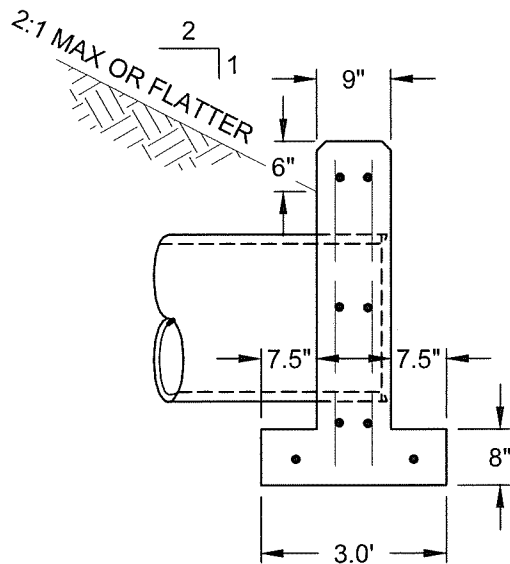

SECTION

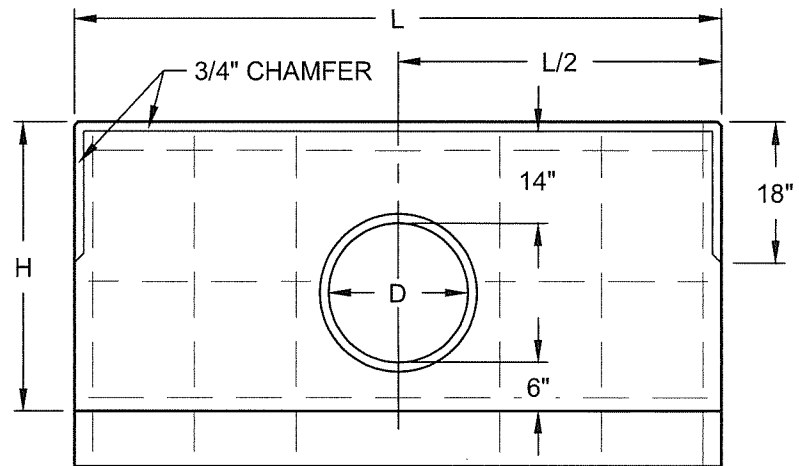

PLAN

NOTES:

1. Concrete - Class 560-C-3250 per Standard Specifications for Public Works Construction (Green Book).
2. Reinforced steel - all horizontal and vertical bars shall be #4 at maximum 18-inch spacing.
3. 3-inch radius around edge at pipe inlet.
4. Double inlet wall - same as single D/2 or 2-foot minimum spacing between pipe inside diameters.

| D (IN.) | H (FT.) | SINGLE | | | DOUBLE | | |
|------------|------------|------------|-----------------|-----------------|------------|-----------------|-----------------|
| | | L (FT.) | STEEL (LBS.) | CONC. (C.Y.) | L (FT.) | STEEL (LBS.) | CONC. (C.Y.) |
| 18 | 3.17 | 7.0 | 50 | 0.91 | 10.5 | 75 | 1.35 |
| 21 | 3.42 | 7.5 | 60 | 1.02 | 11.5 | 90 | 1.52 |
| 24 | 3.67 | 8.5 | 75 | 1.20 | 12.5 | 100 | 1.72 |
| 27 | 3.92 | 9.5 | 85 | 1.39 | 14.0 | 115 | 2.00 |
| 30 | 4.17 | 10.0 | 85 | 1.52 | 15.0 | 126 | 2.21 |
| 33 | 4.50 | 11.0 | 100 | 1.73 | 16.0 | 130 | 2.42 |
| 36 | 4.67 | 12.0 | 105 | 1.95 | 17.0 | 145 | 2.65 |
| 39 | 4.92 | 12.5 | 130 | 2.09 | 18.0 | 170 | 2.88 |
| 42 | 5.17 | 13.5 | 140 | 2.34 | 19.0 | 185 | 3.13 |
| 45 | 5.42 | 14.5 | 150 | 2.60 | 20.0 | 195 | 3.38 |
| 48 | 5.67 | 15.0 | 160 | 2.75 | 21.0 | 200 | 3.64 |



PIPE HEADWALL

| | | |
|--------------------|--|----------------|
| STREETS: <i>Mc</i> | REV. DATE: 11/12 | DETAIL: D-06.0 |
| TRANS OPS: | APPROVED: <i>Pat Telf</i> | |
| FACILITIES: | CITY ENGINEER | |
| WATER RESOURCES: | <i>Christina Anderson</i> PUBLIC WORKS DIRECTOR | |