



# Penfield & Smith

111 East Victoria Street  
Santa Barbara, CA 93101

tel 805-963-9532  
fax 805-966-9801

[www.penfieldsmith.com](http://www.penfieldsmith.com)

Santa Barbara  
Camarillo  
Santa Maria  
Lancaster

Civil Engineering

Land Surveying

Land Use Planning

Construction  
Management & Inspection

Traffic & Transportation  
Engineering

Transportation Planning

Structural Engineering

Water Resources  
Engineering

GIS

W.O. 18767.02

July 30, 2010

Ms. Lisa Arroyo  
City of Santa Barbara  
630 Garden Street  
Santa Barbara, CA 93101

Subject: Lower Sycamore Creek Drainage Improvements Project  
Bridge Selection Evaluation

Dear Ms. Arroyo:

As part of the Lower Sycamore Creek Drainage Improvements Project scope, we have been tasked with briefly evaluating the various bridge types that would be appropriate for the road crossings at Punta Gorda Street and Indio Muerto Street. In preparation for this evaluation, we have reviewed the Caltrans hydraulic evaluation report and coordinated with prefabricated bridge manufacturers, and consulted sources on general cost and construction methods. In addition, we have reviewed the Draft Geotechnical Report, Sycamore Creek Enhancement Project dated July 2010.

The existing bridges are as described below:

- Punta Gorda – 21 feet wide by 7.5 feet high opening with concrete bottom
- Indio Muerto – double 8.5 feet wide by 8 feet high RCB

The bridge types evaluated are:

- Reinforced Concrete Box Culvert (RCB) – Double Box Caltrans Design
- Reinforced Concrete Box Culvert - Single Box Custom Design
- Conventional Bridge
- Conspan Prefabricated Bridge

See the attached exhibits.

The proposed bridges should have a natural bottom to enhance fish passage. The draft geotechnical report has indicated that bridge footings (for the conventional and prefabricated bridge) would need to be supported with piles. The approximate size of the proposed bridge openings should be:

- Punta Gorda – 240 square feet

- Indio Muerto – 200 square feet

The following tables summarize the cost, advantages and disadvantages. All costs are concept level in detail and include only the actual bridge and foundation construction. Utility relocation, road construction, special design features, dewatering, adjacent foundation protection, transition walls, etc are not included.

**Table 1 - Reinforced Concrete Box Culvert – Double Box – Caltrans Design**

Cost	Advantages	Disadvantages
\$250,000 – Punta Gorda \$210,000 – Indio Muerto	Cost effective	Has a vertical wall in the middle that catches debris and encourages plugging <sup>1</sup> during flood events.
	Can be constructed with precast parts which would enable quicker construction	Has a concrete bottom which would necessitate deeper excavation so that environmental fill could be placed.
	Thinner bridge deck which may allow a narrower bridge width	More complicated dewatering
	Does not require piles which could be an environmental issue (noise)	Most wet concrete in bottom of channel
Notes: 1. The Flood Control District has already indicated significant concern about this type of construction.		

**Table 2 - Reinforced Concrete Box Culvert - Single Box - Custom Design**

Cost	Advantages	Disadvantages
\$380,000 – Punta Gorda \$360,000 – Indio Muerto	Natural bottom fill	Has a concrete bottom which would necessitate deeper excavation so that environmental fill could be placed.
	Thinner bridge deck which may allow a narrower bridge width	More complicated dewatering
	Does not require piles which could be an environmental issue (noise)	Most wet concrete in bottom of channel

**Table 3 - Conventional Bridge Construction**

Cost	Advantages	Disadvantages
\$500,000 – Punta Gorda \$450,000 – Indio Muerto	Natural bottom	Least cost effective
	Least amount of excavation	Longest time of construction
	Least amount of dewatering	Requires piles which could be an environmental issue (noise)
	Least likely to be clogged with debris during storm	Thicker bridge deck which may result in a wider bridge opening



Table 4 - Conspan Precast Bridge

Cost	Advantages	Disadvantages
\$250,000 – Punta Gorda \$225,000 – Indio Muerto	Cost effective	Shortest time of construction
	Natural bottom	Requires piles which could be an environmental issue (noise)
	Moderate amount of excavation (in between RCB and Conventional Bridge)	Moderate bridge deck thickness (in between RCB and Conventional Bridge)
	Least amount of dewatering	
	Least likely to be clogged with debris during storm	
	Least amount of wet concrete in creek bottom	

Our recommendation for this project would be to use a bridge product similar to the Conspan Precast Bridge because of the limited impact to the creek (less dewatering, earthwork and wet concrete in the channel), less disruption to the neighborhood due to short construction time, and low cost. The use of Cast-In-Drill-Hole Piles (CIDH) will reduce the amount of noise involved with installing piles.

If you have any questions, please feel free to contact me at (805) 963-9538 extension 124.

Very truly yours,  
PENFIELD & SMITH

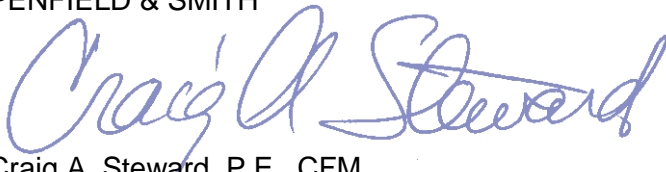

Craig A. Steward, P.E., CFM  
Principal Engineer  
RCE 37,253



STANDARD BRIDGE				
	LENGTH	WIDTH	RISE	COST
PUNTA GORDA	50 FT	28 FT	8.5 FT	\$500,000
INDIO MUERTO	53 FT	24 FT	8.5 FT	\$450,000

NOTE: COSTS ARE ORDER OF MAGNITUDE COSTS FOR STRUCTURE ONLY AND DOES NOT INCLUDE EXCAVATION, UTILITY RELOCATIONS, ROAD WORK, DEWATERING, OR WING WALLS.

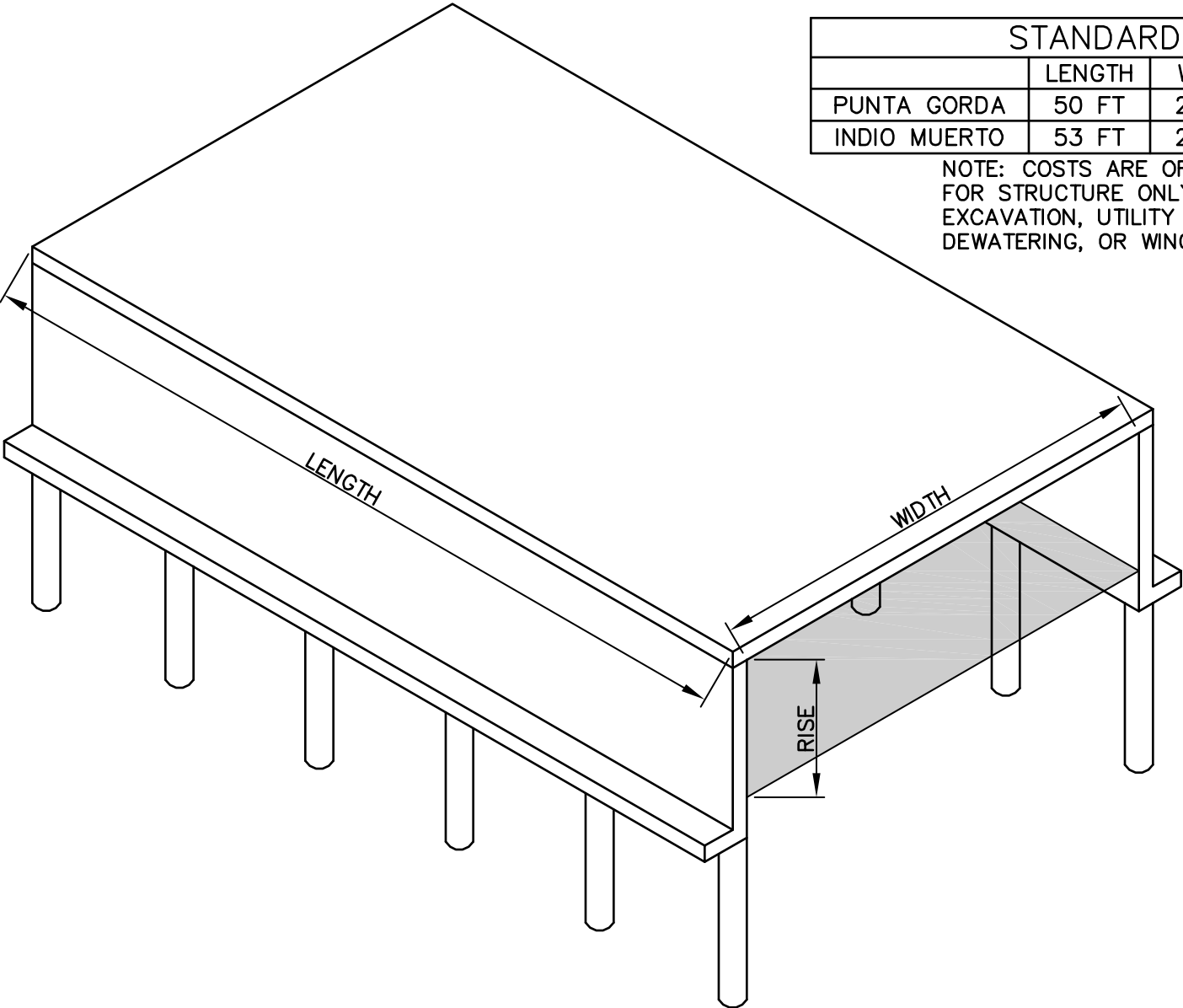

**SYCAMORE CREEK DRAINAGE IMPROVEMENT PROJECT  
STANDARD BRIDGE**

JULY 30, 2010

SCALE: 1"=10'





**Penfield & Smith**  
Engineering · Surveying · Planning  
· Construction Management ·

### CONSPAN BRIDGE SYSTEM

	LENGTH	WIDTH	RISE	COST
PUNTA GORDA	50 FT	32 FT	9 FT	\$250,000
INDIO MUERTO	53 FT	28 FT	8 FT	\$225,000

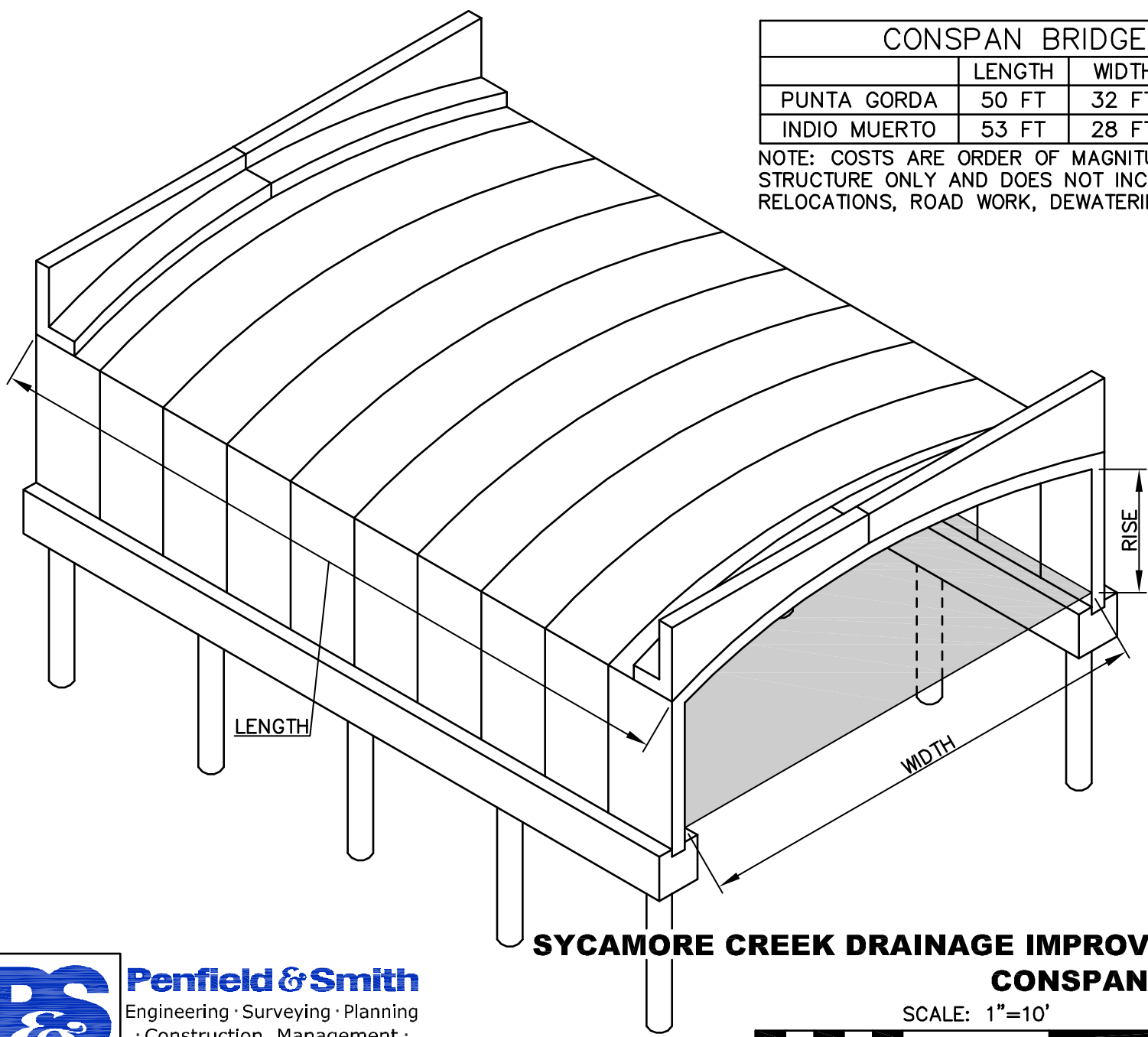
NOTE: COSTS ARE ORDER OF MAGNITUDE COSTS FOR STRUCTURE ONLY AND DOES NOT INCLUDE EXCAVATION, UTILITY RELOCATIONS, ROAD WORK, DEWATERING, OR WING WALLS.



### SYCAMORE CREEK DRAINAGE IMPROVEMENT PROJECT CONSPAN BRIDGE SYSTEM

JULY 30, 2010

SCALE: 1"=10'



**Penfield & Smith**  
Engineering · Surveying · Planning  
· Construction Management ·

BOX CULVERT					
	LENGTH	WIDTH	RISE*	TYPE	COST
PUNTA GORDA	50 FT	29 FT	10.5 FT	DBL RCB	\$250,000
INDIO MUERTO	53 FT	25 FT	10 FT	DBL RCB	\$210,000

NOTE: COSTS ARE ORDER OF MAGNITUDE COSTS FOR STRUCTURE ONLY AND DOES NOT INCLUDE EXCAVATION, UTILITY RELOCATIONS, ROAD WORK, DEWATERING, OR WING WALLS.  
 \*INCLUDES ENVIRONMENTAL FILL

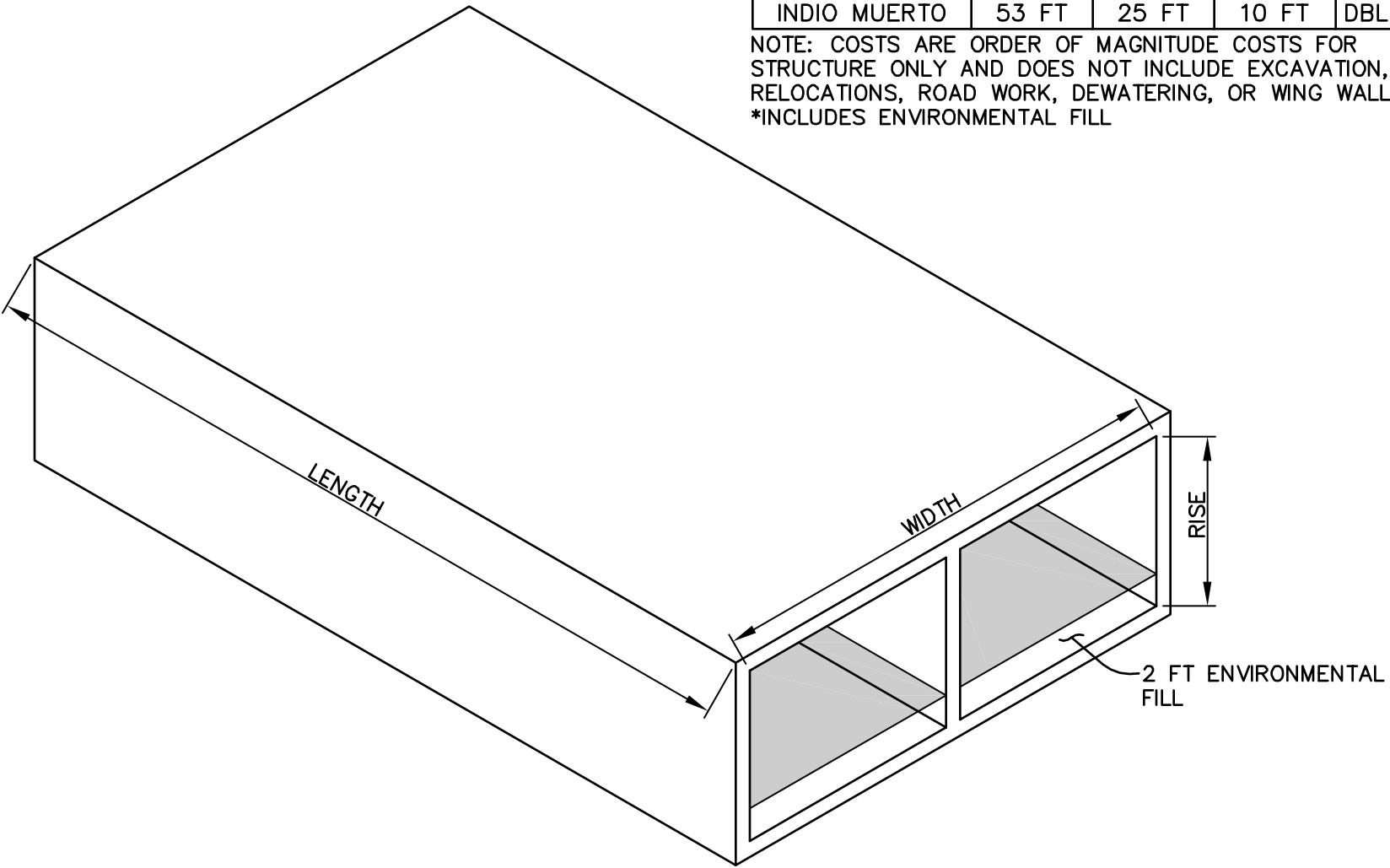

**SYCAMORE CREEK DRAINAGE IMPROVEMENT PROJECT**  
**BOX CULVERT - DOUBLE SPAN - CALTRANS DESIGN**

SCALE: 1"=10'

JULY 30, 2010



**Penfield & Smith**  
 Engineering · Surveying · Planning  
 · Construction Management ·

BOX CULVERT					
	LENGTH	WIDTH	RISE*	TYPE	COST
PUNTA GORDA	50 FT	29 FT	10.5 FT	RCB	\$380,000
INDIO MUERTO	53 FT	25 FT	10 FT	RCB	\$360,000

NOTE: COSTS ARE ORDER OF MAGNITUDE COSTS FOR STRUCTURE ONLY AND DOES NOT INCLUDE EXCAVATION, UTILITY RELOCATIONS, ROAD WORK, DEWATERING, OR WING WALLS.  
 \*INCLUDES ENVIRONMENTAL FILL

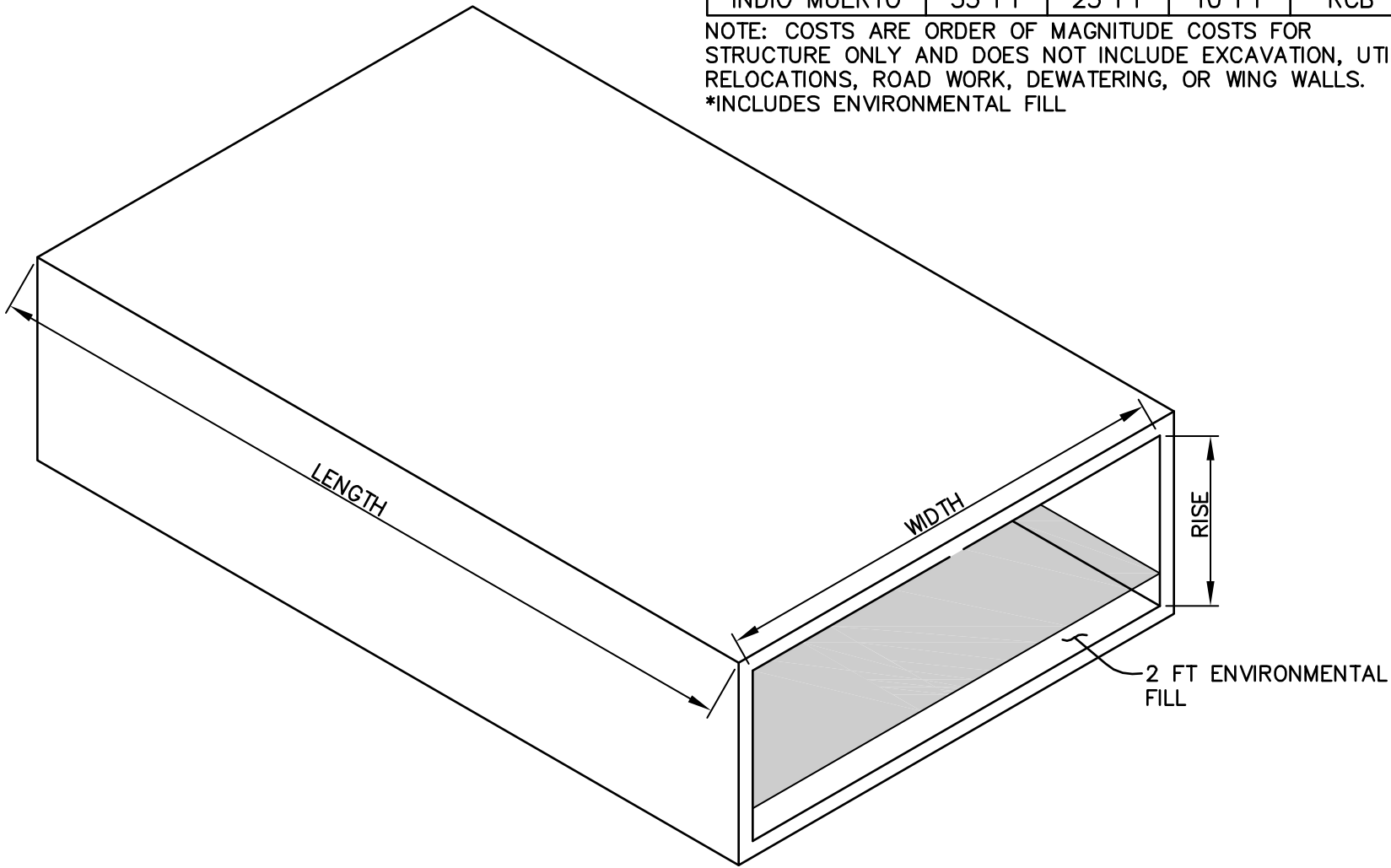

**SYCAMORE CREEK DRAINAGE IMPROVEMENT PROJECT**  
**BOX CULVERT - SINGLE SPAN - CUSTOM DESIGN**

SCALE: 1"=10'

JULY 30, 2010



**Penfield & Smith**  
 Engineering · Surveying · Planning  
 · Construction Management ·