

City of Santa Barbara

UPDATED 10-31-

# REQUIREMENTS FOR OPERATING A BUSINESS ON THE TEMPORARY STATE STREET PROMENADE



**City of Santa Barbara**  
**PUBLIC WORKS DEPARTMENT**  
DOWNTOWN PARKING  
(805) 564-5656

# REQUIREMENTS FOR OPERATING A BUSINESS ON THE TEMPORARY STATE STREET PROMENADE

---

The City of Santa Barbara welcomes businesses operating on the 400 through 1300 blocks of State Street to temporarily expand operations into the street to facilitate economic recovery in the wake of the COVID-19 pandemic. Any business wishing to operate an outdoor business facility in the State Street Promenade must adhere to these requirements, as authorized by Ordinance No. 6055 (ERETO).

**Any violation of these requirements is subject to enforcement action under Ordinance No. 6055, and may result in fines, criminal prosecution, suspension of on-street operation privileges, and removal of a facility from the right-of-way.**

**Outdoor business facilities in the Right-of-Way are Temporary:** The City of Santa Barbara reserves the right to remove any materials placed in the right-of-way at its sole discretion.

The City is not responsible for loss or damage to outdoor business facilities placed in the public right-of-way.

Business Contact: For questions and additional guidance, email [SClark@SantaBarbaraCAgov](mailto:SClark@SantaBarbaraCAgov).



## **INSURANCE REQUIREMENTS**

By placing facilities, equipment, and furnishings in the public right-of-way under the ERETO, the owner agrees to defend and indemnify the City and its officers, employees, and agents from and against any liability arising from the existence, use, or condition of the facilities, equipment, or furnishings. All persons and businesses that establish outdoor business facilities in the public right-of-way must provide a certificate of insurance from their business insurance carrier naming the City and its officers, employees, and agents as additionally insureds. Please send insurance certificates to [OutdoorDining@SantaBarbaraCA.gov](mailto:OutdoorDining@SantaBarbaraCA.gov).

## **FIRE LANE REQUIRED**

A 20-foot wide fire lane has been established for the State Street Promenade. Outdoor business facilities and outdoor operations are prohibited in the fire lane. For State Street Promenade Fire Lane maps, visit: [https://santabarbaraca.gov/sites/default/files/documents/PIO/Communications/State\\_Street\\_Fire\\_Lane\\_Map.pdf](https://santabarbaraca.gov/sites/default/files/documents/PIO/Communications/State_Street_Fire_Lane_Map.pdf)

## **SIDEWALK ENCROACHMENT PROHIBITED**

Business operations in the public right-of-way, including customer seating, umbrellas, lighting, heaters, signs, and other displays are prohibited on the sidewalk except as permitted for businesses that have applied for and been issued an Outdoor Dining License Agreement.

## **UTILITIES**

Outdoor business facilities must not obstruct access to public utilities.

## **DAMAGE TO CITY PROPERTY**

Outdoor business facilities and fixtures must not damage the pavement, landscaping, lighting, street trees, or any other City property. Outdoor business facilities and accessory facilities may not be attached to or hung from light poles, sign posts, or street trees.



## ACCESSIBILITY REQUIREMENTS

**It is the responsibility of each business operator to provide outdoor dining in full compliance with accessibility requirements of the Americans with Disabilities Act (ADA) and the California Building Code (CBC).** The requirements listed below were developed as part of the overall State Street requirements to assist restaurant operators with meeting these requirements. Nothing contained herein shall replace or diminish any of the requirements under the ADA or CBC. Businesses are encouraged to retain the services of a Certified Access Specialist (CASP) to assist in the design and configuration of their facilities.



**REQUIREMENTS FOR OPERATING A BUSINESS ON THE TEMPORARY STATE STREET PROMENADE**

**Where access to an outdoor business facility is not level, an access ramp must be provided.** Ramps must comply with California Building Code Chapter 11B, summarized as follows:

- ▶ Ramps must be at least 4 feet wide.
- ▶ 8.3% (1:12) maximum running slope (parallel to the direction of travel). If slope is greater than 5%, handrails must be provided on both sides of the ramp.
- ▶ 2% maximum cross slope (perpendicular to the direction of travel).
- ▶ Level landings at the top and bottom of the ramp measuring at least 4 feet by 4 feet.
- ▶ Accessible, unobstructed path of travel from the sidewalk pedestrian path to the ramp.
- ▶ Edge protection is required on each side of the ramp. A curb or barrier that prevents the passage of a 4-inch diameter sphere must be provided along both edges of the ramp. To prevent wheel entrapment, the edge protection must provide a continuous, uninterrupted barrier along the edge of the ramp.
- ▶ Ramp must be firm, stable, and slip-resistant.
- ▶ Ramp must be securely attached so that it does not move or shift during use.
- ▶ Ramp must not have abrupt vertical edges (“lips”) or variations over ½ inch in height. Edges or changes in height between ¼ and ½ inch must be beveled to provide a smooth transition.

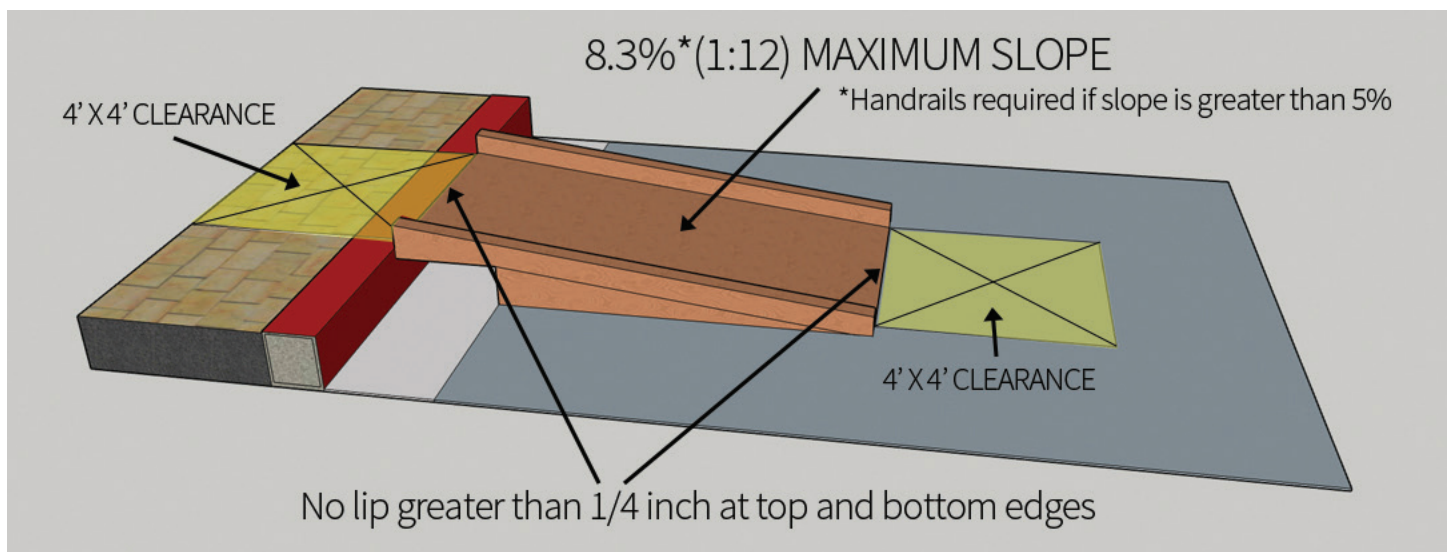

**REQUIREMENTS FOR OPERATING A BUSINESS ON THE TEMPORARY STATE STREET PROMENADE**

**Vertical clearance (distance to any overhead element, including lighting and umbrellas) must be a minimum of 80 inches.** If clearance is less than 80 inches, guards or handrails are required.

For beverage and dining establishments, **at least 5% of the seating spaces and 5% of the standing spaces shall be accessible.** Accessible spaces must meet the following requirements:

- ▶ The table or counter surface must be between 28 and 34 inches high.
- ▶ The space between the floor and the bottom of the table or counter must be at least 27 inches high.
- ▶ Knee clearance must extend at least 19 inches under the table or counter. Knee clearance is measured from the edge of the table or counter to the outside edge of any obstruction under the table or counter, including table legs and bases. Pedestal-style tables are not accessible.
- ▶ Table or counter legs, bases, or supports must be at least 30 inches apart, as measured from the narrowest point.
- ▶ Each seat must have at least 30 inches by 48 inches of clear floor area and must be at least 4 feet from the nearest obstruction.
- ▶ The International Symbol of Accessibility must be displayed at the table(s).
- ▶ An accessible path of travel at least 44 inches wide must be maintained to the accessible table(s).
- ▶ Accessible dining tables and surfaces must be dispersed throughout the space.

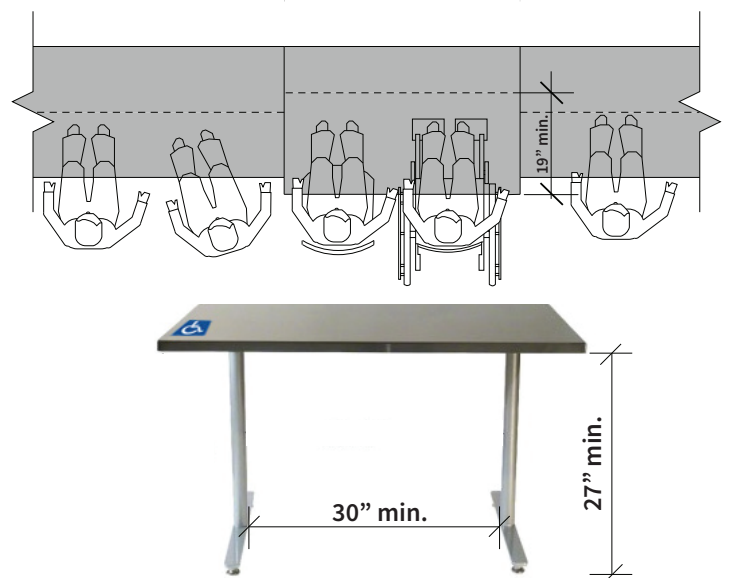
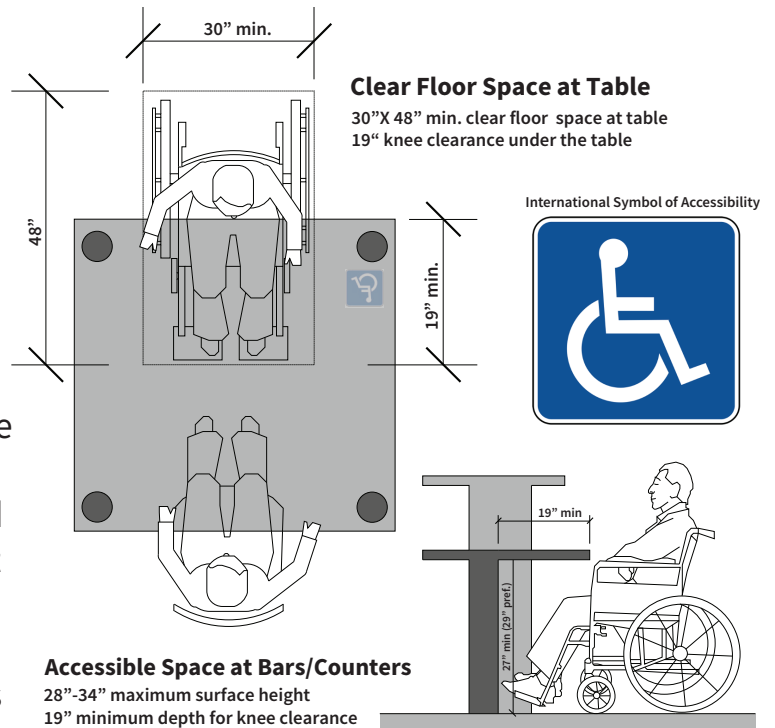

**DRAINAGE AND STORM FLOW**

**Businesses must implement the Drainage and Storm Flow requirements in this section by December 1, 2022.**

To accommodate drainage and storm water, all outdoor business facilities must provide continuous, unobstructed clear space equal to the height of the curb and width of the gutter apron, at a minimum. The entire length of this space must be accessible for cleaning. Outdoor business facilities without platforms and operating on State Street shall not place or store their furnishings in or on the gutter apron.

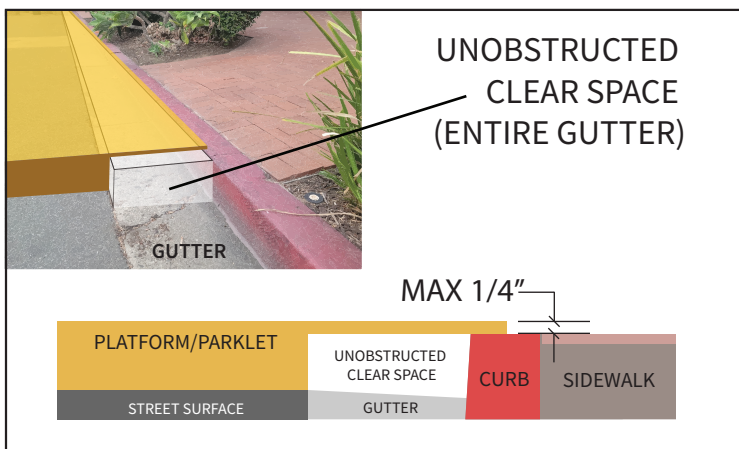

**DESIGN REQUIREMENTS**

*Businesses must implement the Design Requirements in this section by February 1, 2023.*

On-street business facilities constructed and operating prior to September 20, 2022 must implement the design requirements in this section by February 1, 2023. Existing facilities are not required to implement design standards that apply only to new facilities, as indicated in this section.

Some design requirements apply only to “**new**” business facilities. A “**new**” business facility is an on-street business facility that was not fully constructed, placed, and operational as of September 20, 2022. Facilities that are re-built following suspension of on-street operations privileges due to code or ordinance violations are considered **new**. **New** outdoor business facilities must be in compliance with all design requirements before

**REQUIREMENTS FOR OPERATING A BUSINESS ON THE TEMPORARY STATE STREET PROMENADE**

---

they begin operations.

On-street business facilities that were constructed and operational in the State Street Promenade, including the 400 and 1300 blocks of State Street, as of September 20, 2022 are considered existing facilities and are exempt from some design requirements, as specified below. A business that removes its on-street facility but replaces it prior to June 1, 2023, may retain its “existing” status, provided the business does not change during that period.

***PORTABILITY AND CLEANING***

All outdoor business facilities with platforms, including those operating prior to September 20, 2022, must be designed and constructed so that the area under the platform is fully accessible for cleaning.

**New** on-street business facilities must be portable. A “portable” facility is a facility that can be completely removed from the street with 24 hours’ notice, without the use of mechanized equipment. Portable facilities should be secured as needed for safety.

***ENCLOSURES AND RAILINGS***

Lattice and picket fence-style enclosures are prohibited on all outdoor business facilities.

For **new** on-street business facilities:

- ▶ Enclosures and railings are limited to a maximum height of 48 inches.
- ▶ Curtains, walls, or enclosures of any type are prohibited above 48 inches.
- ▶ Enclosures and barriers must incorporate space between railings to provide visibility to the architecture from the street.
- ▶ Solid enclosure materials are prohibited.

***GROUND COVER AND PLATFORM SURFACES***

Turf grass, faux lawn materials, and carpet are prohibited in all outdoor business facilities.





**REQUIREMENTS FOR OPERATING A BUSINESS ON THE TEMPORARY STATE STREET PROMENADE**

---

**ROOFS AND OVERHEAD ELEMENTS**

Outdoor business facilities may incorporate posts at the perimeter to support string lighting. Posts are limited to maximum height of 10 feet as measured from the ground or the surface of a platform, as applicable.

For **new** on-street business facilities that begin operations after September 20, 2022, roofs, canopies, tents, and any other overhead elements are prohibited. Umbrellas are permitted, but must be contained entirely within the business facility and may not extend into the 20-foot access lane.

**Safety Regulations for All Overhead Elements**

The following requirements shall apply to the use of roofs, tents, canopies, or any form of overhead shade structures (herein referred to as “overhead elements”) in outdoor business facilities. These requirements must be adhered to any time an overhead element is in use.

- ▶ The operation of temporary outdoor business facilities under tents and other membrane structures is subject to the requirements of the California Code of Regulations, Title 19, Division 1; and Chapters 3 and 31 of the California Fire Code.
- ▶ All tents, canopies, and overhead elements are subject to Fire Department inspection.
- ▶ Tents, canopies, and overhead elements require a Fire Department permit if they exceed 700 square feet (call 805-965-5254 for permit information).
- ▶ All tent material must be treated for flame resistance in accordance with an approved State Fire Marshal method or be of a fabric that is inherently flame resistant, regardless of whether a permit is needed.
- ▼ Tents, canopies, and other overhead elements must be adequately roped, braced, and anchored to withstand the elements and avoid collapsing.
  - ▶ All tent supports or legs must be weighted with a minimum of 40 pounds.
  - ▶ Ropes and straps must be high-quality. Bungee or rubber straps are prohibited.
  - ▶ Weights must be on the ground and not dangling.
  - ▶ Weights and lines must be clearly visible and must not pose a hazard.

For maximum safety, tents should be secured as soon as they are put up, and taken down as soon as the weight is removed. Do not leave tents unsecured at any time.



**REQUIREMENTS FOR OPERATING A BUSINESS ON THE TEMPORARY STATE STREET PROMENADE**

---

- ▶ Staking of tents is prohibited in the public right-of-way.
- ▶ Tethering or securing tents, canopies, or overhead elements to trees is prohibited.
- ▶ A facility with a tent, canopy, or overhead element is required to have two means of egress if the occupant load exceeds 10.
- ▶ Seating arrangements are subject to Chapter 10 of the Fire and Building Codes.
- ▶ Smoking is prohibited under tents, canopies, and overhead elements at all times.

***FURNITURE***

Plastic and vinyl patio furniture is prohibited. White furniture is prohibited.

***LIGHTING***

All lighting must be powered by City pedestals or portable electric power sources (supplied by the business). Gas and diesel generators are prohibited. For access to City power pedestals, please contact Mark Nunez at [MNunez@SantaBarbaraCA.gov](mailto:MNunez@SantaBarbaraCA.gov).

Lighting must be self-contained within the on-street business facility. Stringing lights or running electrical cords across sidewalks is prohibited. Lights may not be attached to or strung through trees.

The following types of lighting are prohibited:

- ✘ Neon
- ✘ Flashing lights
- ✘ Spotlights

***SCREENS AND PROJECTORS***

Screens and televisions may not be mounted on the exterior of buildings. Projection onto the exterior of buildings is prohibited.

***SIGNS, LOGOS, BANNERS, AND ADVERTISING***

Visible advertising, logos, banners, and promotional materials are prohibited in, on and around all outdoor business facilities. Umbrellas may not have lettering or logos.

A-frames, sandwich boards, and all other free-standing signs are prohibited on sidewalks and in the street.



**REQUIREMENTS FOR OPERATING A BUSINESS ON THE TEMPORARY STATE STREET PROMENADE****COLORS**

Platforms, barriers, and other enclosure materials must be stained, painted, or colored one of the following approved colors:

<https://santabarbaraca.gov/santa-barbara-colors> (Iron colors only)



White furniture is prohibited.

### **PORTABLE HEATERS, OUTDOOR FIREPLACES, AND HEATING ELEMENTS**

Portable heaters are permitted, however, please ensure proper clearance to trees, awnings, and umbrellas to avoid fire hazards. Heaters must be self-contained, with no wires or other trip hazards.

- ▶ Heating equipment is subject to Section 3104 of the 2019 Fire Code and requires Fire Department approval.
- ▶ All heaters are subject to Fire Department inspection.
- ▶ Gas heaters must adhere to the California Mechanical Code.
- ▶ Heating equipment located under a tent, canopy, or roof may not be located within 10 feet of the facility exit.
- ▶ Gas equipment shall be vented to the exterior. If such venting requires a flue, the pipe shall not be installed within 12 inches of the tent fabric.
- ▶ Electrical heaters shall be installed pursuant to the California Electrical Code.
- ▶ Clearance from any ignition source to any combustible material must be maintained in an approved manner.
- ▶ Portable or fixed outdoor fireplaces shall not be operated within 15 feet of a combustible surface.
- ▶ Candles may only be used in approved and stable candle holders on individual tables in dining establishments. Under no circumstances shall hand-held candles be permitted.
- ▶ Outdoor cooking is prohibited.
- ▶ In the event strict compliance is not achievable, alternate but equally effective means of compliance must be approved by the Fire Department.



**REQUIREMENTS FOR OPERATING A BUSINESS ON THE TEMPORARY STATE STREET PROMENADE**

- ▶ Storage of LP-Gas containers shall comply with section 6109 of the 2019 Fire Code.

**OPERATING STANDARDS**

- ▶ Santa Barbara is a Smoke-Free City. Smoking is prohibited in outdoor business facilities at all times.
- ▶ Outdoor business facilities must be removed from the right-of-way immediately upon permanent closure of the associated business. Any outdoor business facility constructed or placed by subsequent tenants is considered **new**.
- ▶ Outdoor business facilities must remain in good repair and regular use.
- ▶ Outdoor business facilities that are not used at least three days per week must be removed at the business or property owner's expense.
- ▶ Outdoor business facilities that remain unused for 14 consecutive days are considered abandoned and must be removed at the business or property owner's expense.
- ▶ Businesses are responsible for cleaning their outdoor business facilities and keeping them in good condition. Trash, dirt, and debris must be removed from the outdoor business facility daily and disposed of in the business's trash receptacle (not public trash cans). Sweeping or blowing trash or debris into the street, sidewalks, or planters is prohibited.

